

INSTRUCTIONS

#FTF

FERRULE TURNING FIXTURE

Installation on Belt Sander/Buffer Motor (#BSBM) or Shaft Cutting Machine (#SCM)

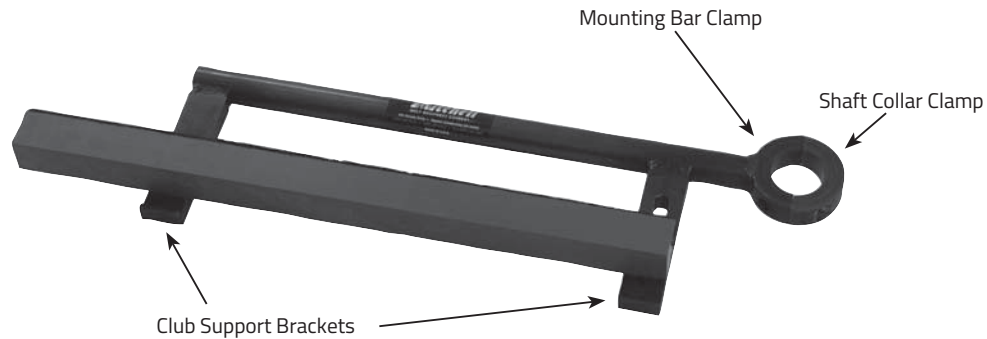

- 1** Loosen two bolts in **Shaft Collar Clamp** using 3/16" Allen wrench & separate from **Mounting Bar Clamp**. Leave bolts in **Shaft Collar Clamp**.
- 2** Use pen to place mark 2-3/4" down from **Locking Collar** on the **Sanding Belt Adjustment Bar**. (Fig. 1)
- 3** With **Club Support Brackets** facing forward, position **Mounting Bar Clamp** on **Sanding Belt Adjustment Bar**. Place **Shaft Collar Clamp** on **Sanding Belt Adjustment Bar** & finger tighten bolts to **Mounting Bar Clamp**.
- 4**

Align **Mounting Bar Clamp** parallel with motor & locate at pen mark on **Sanding Belt Adjustment Bar**. Tighten bolts in **Shaft Collar Clamp** securely with 3/16" Allen wrench.

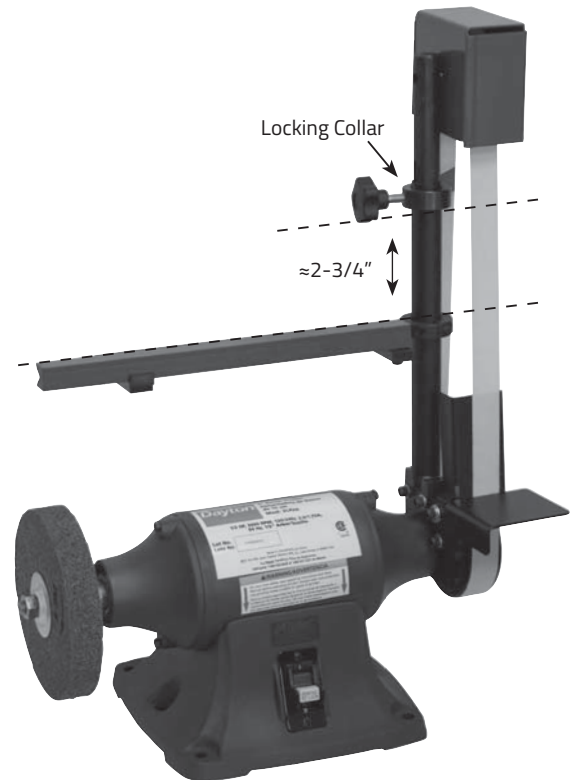

Fig. 1